

# The Corpus of Anglo-Saxon Stone Sculpture

## Volume IV

Tweddle, D, Biddle, M, & Kjølbye-Biddle, B, 1995. Corpus of Anglo-Saxon Stone Sculpture IV

### South East England (Oxford)

This file contains all the figures, maps and tables printed in Volume IV of the Corpus of Anglo-Saxon Stone Sculpture, as they appear in the accompanying chapters.

© All images copyright of Corpus of Anglo-Saxon Stone Sculpture and cannot be reproduced for media or publication purposes without the permission of the project.

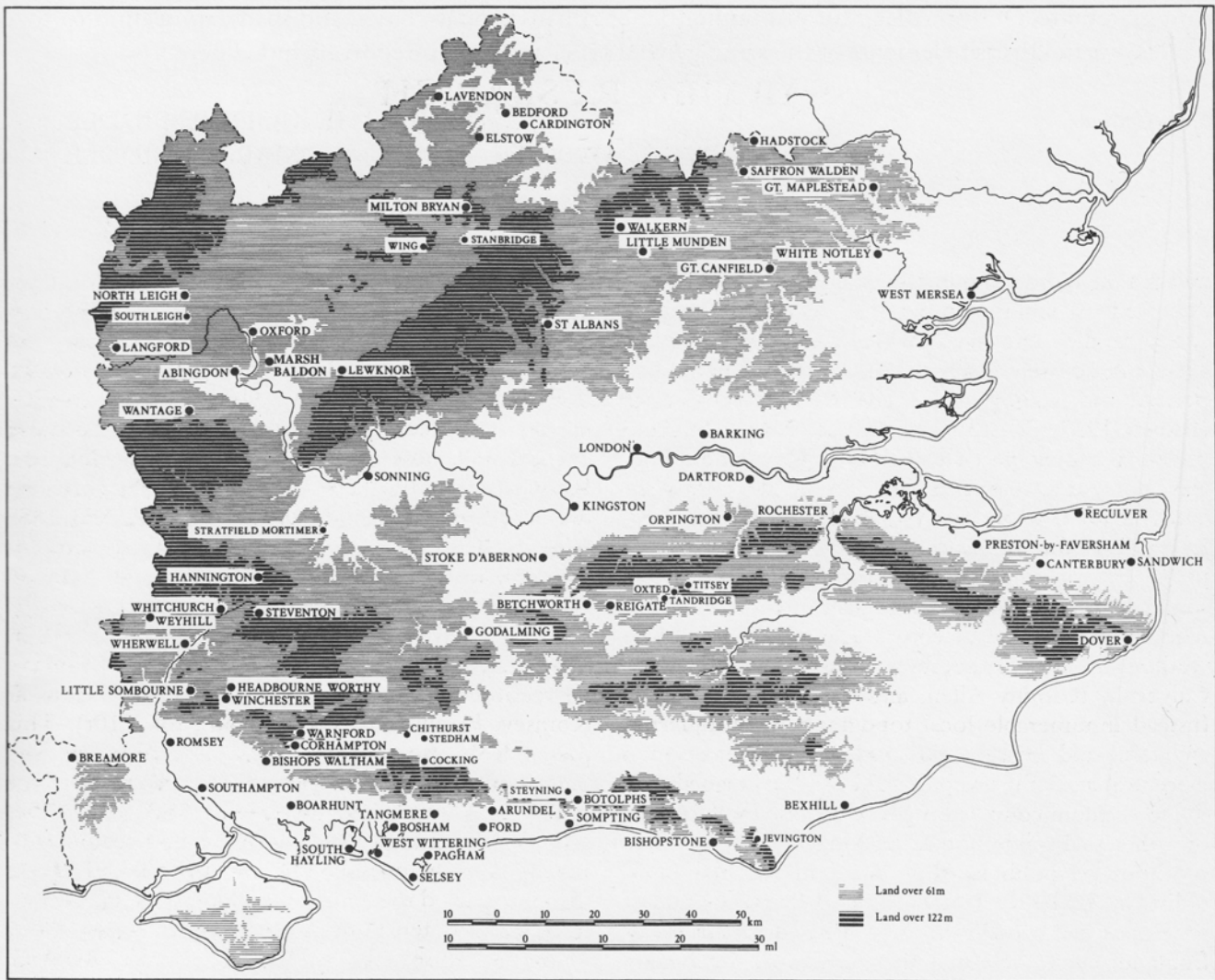

FIGURE 1  
Sites with sculpture in South-East England

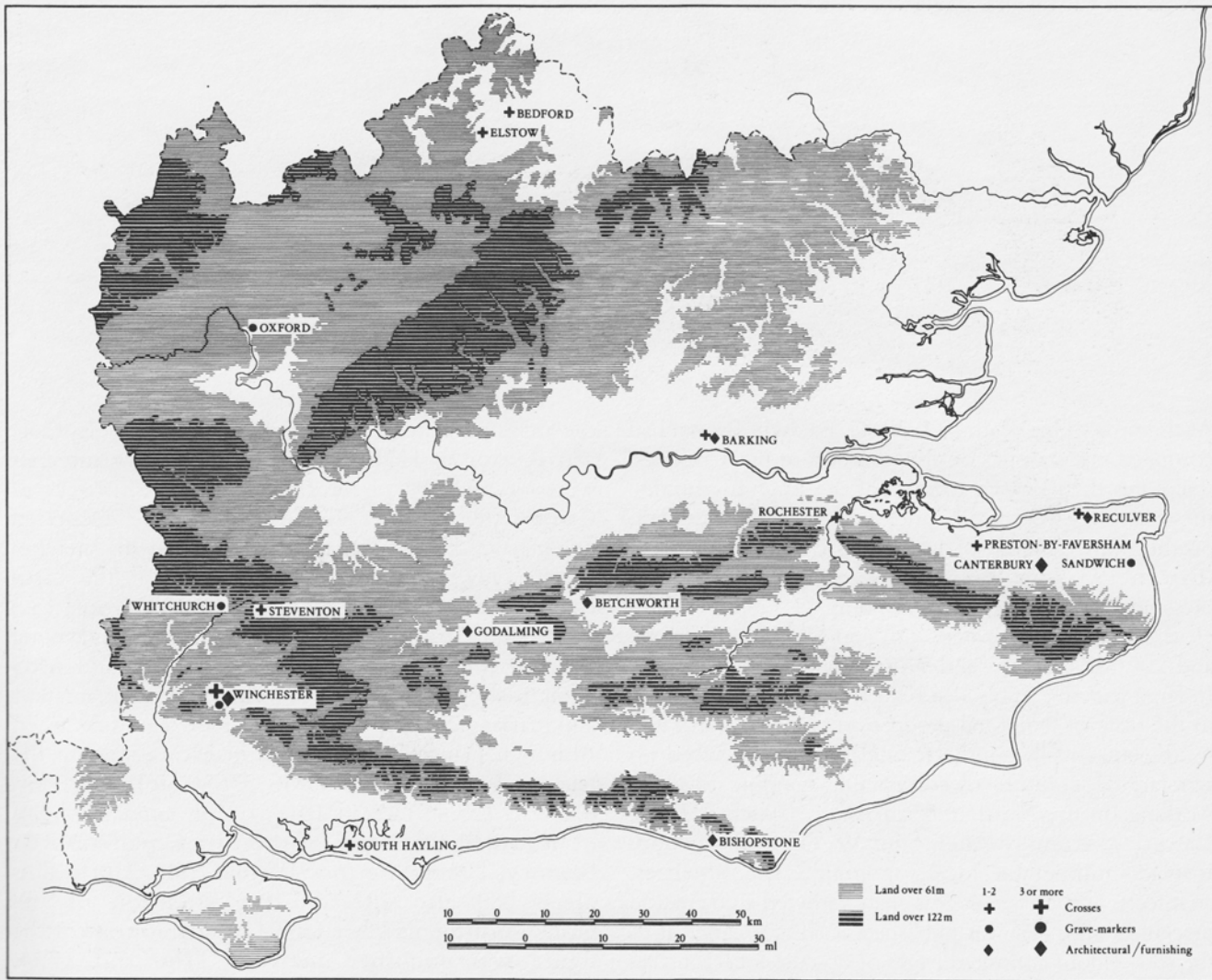

FIGURE 2  
Sculpture earlier than c. 950

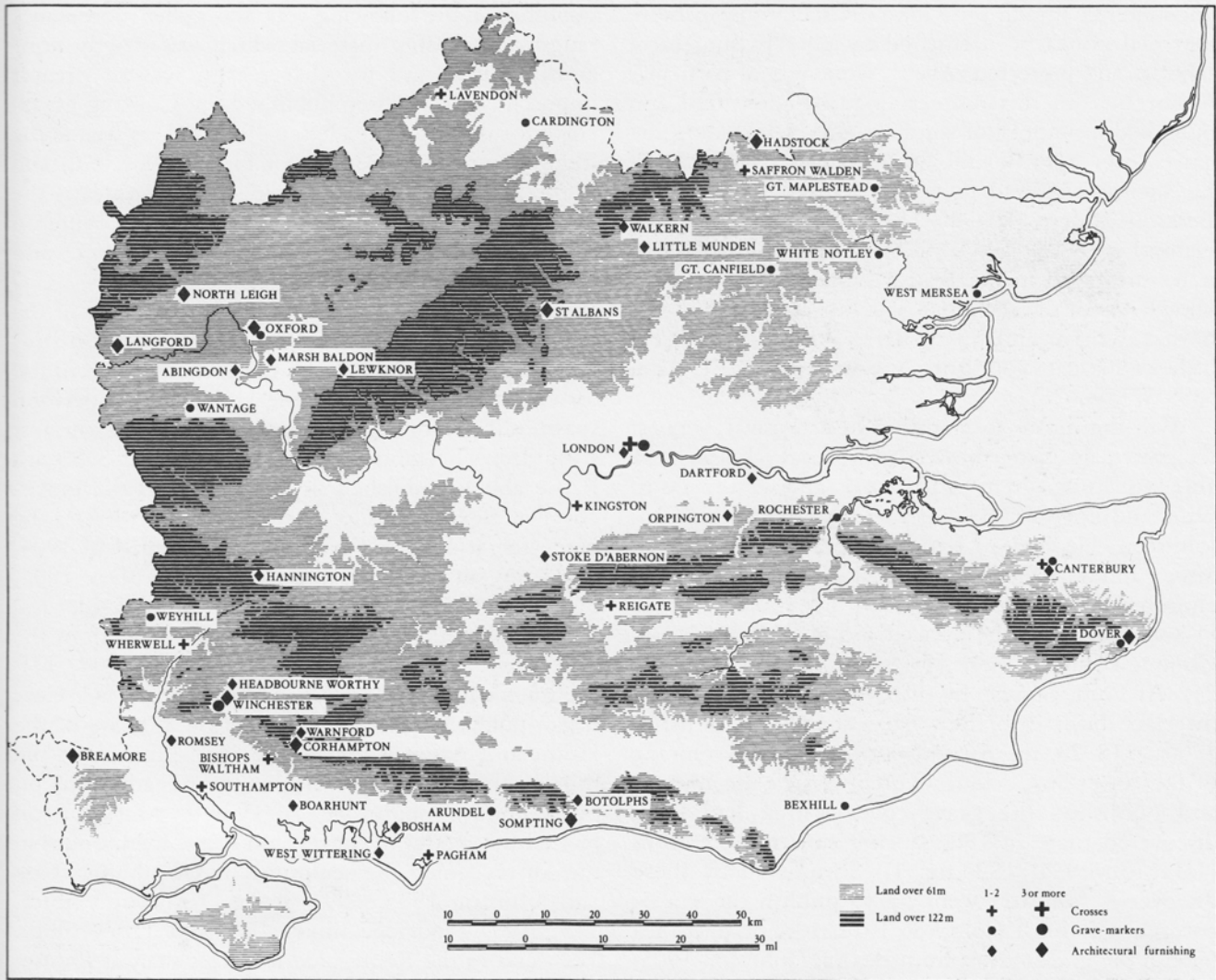

FIGURE 3  
Sculpture later than c. 950

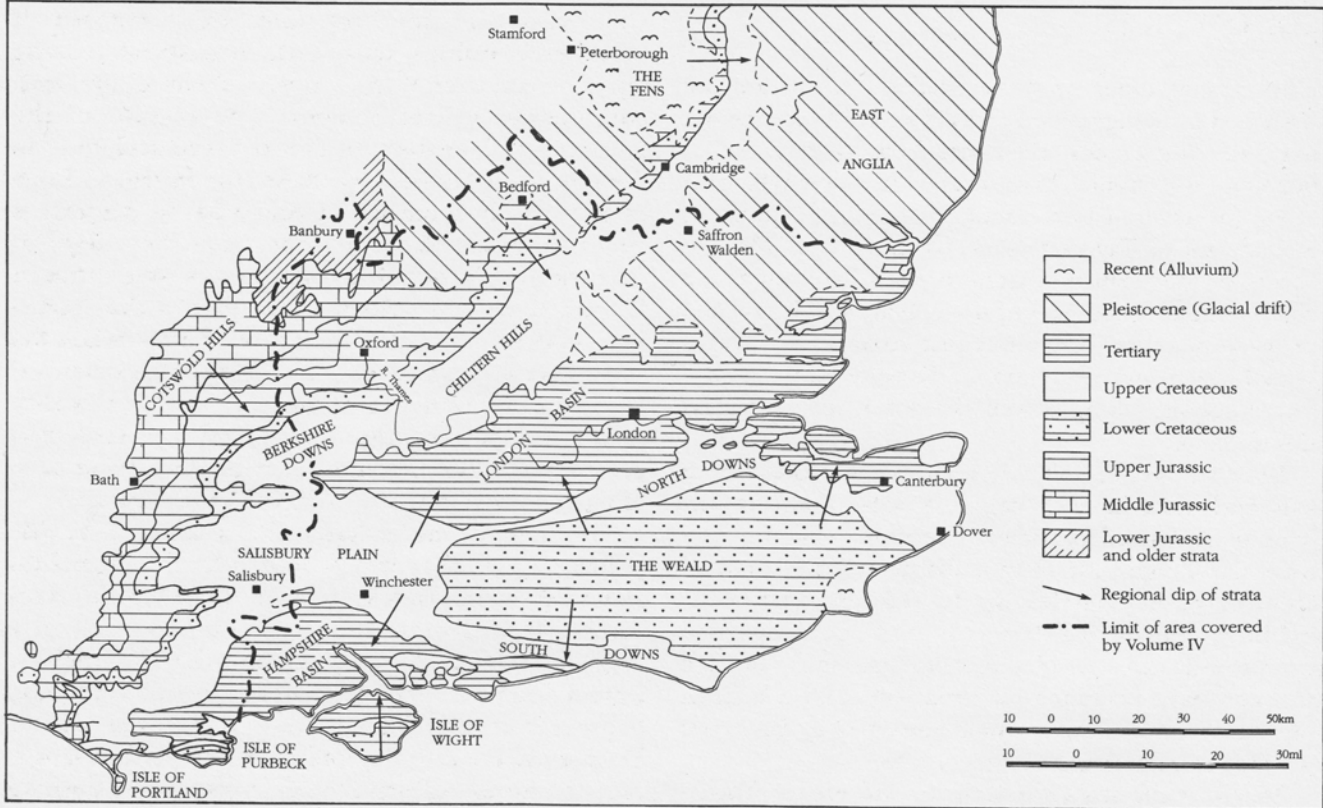

FIGURE 4  
Geology

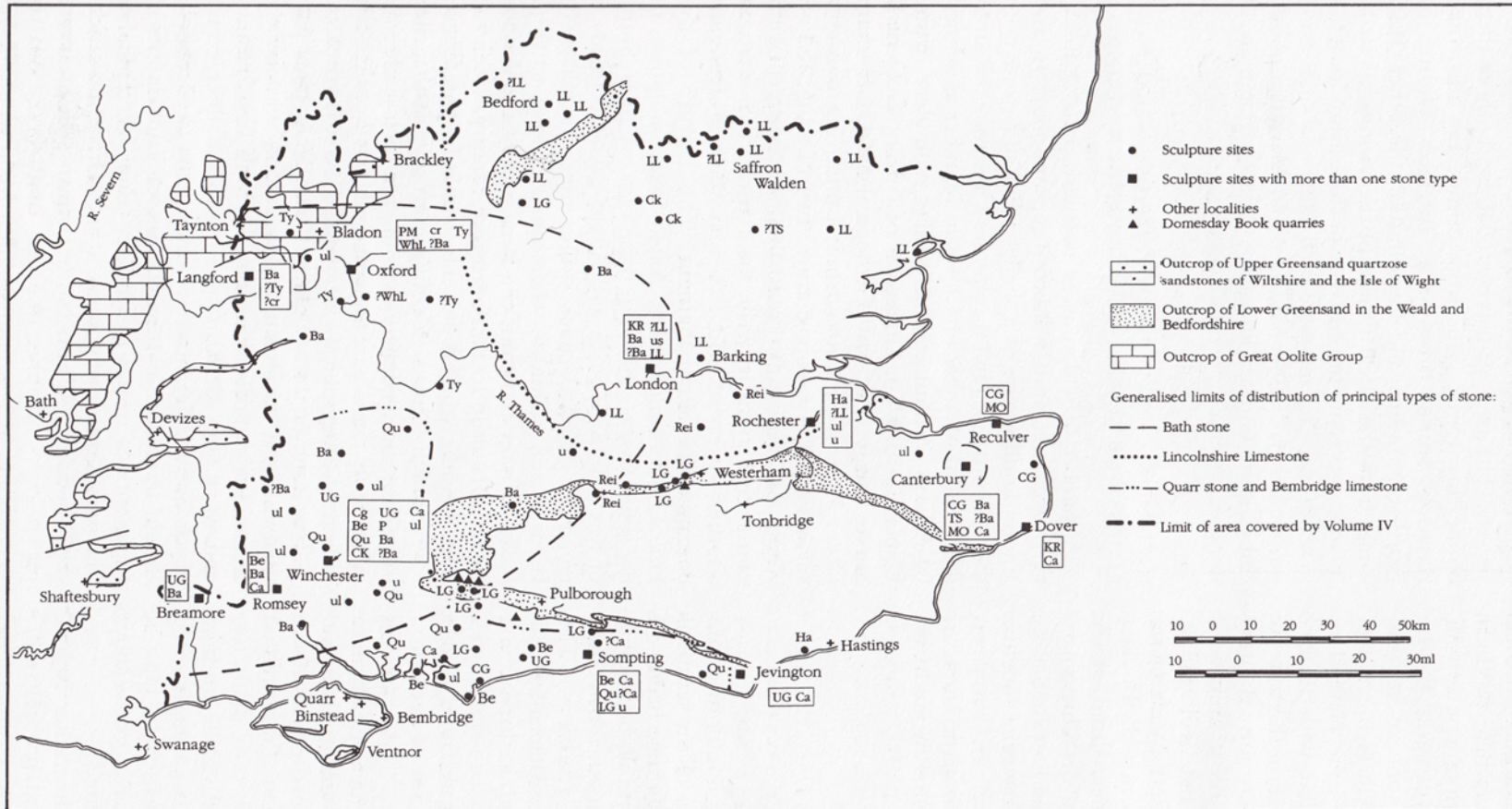

FIGURE 5  
Sources of stone used for Anglo-Saxon sculptures in South-East England

Abbreviations for stone types, in alphabetical order:

Ba	Bath stone	LG	Lower Greensand other than Kentish Rag	TY	Taynton stone
Be	Bembridge limestone	LL	Lincolnshire Limestone	UG	Upper Greensand other than Reigate stone
Ca	Caen stone	MO	Marquise oolite	WhL	White Limestone
CG	Calcaire Grossier	P	Portland stone	ul	unidentified limestone
Ck	Chalk	PM	Purbeck Marble	us	unidentified sandstone
Cr	Corallian limestone	Qu	Quarr stone	u	unidentifiable – stone inaccessible, whitewashed, or missing
Ha	Hastings Beds sandstone	Rei	Reigate stone (Upper Greensand)		
KR	Kentish Rag (Lower Greensand)	TS	Thanet Beds sandstone		

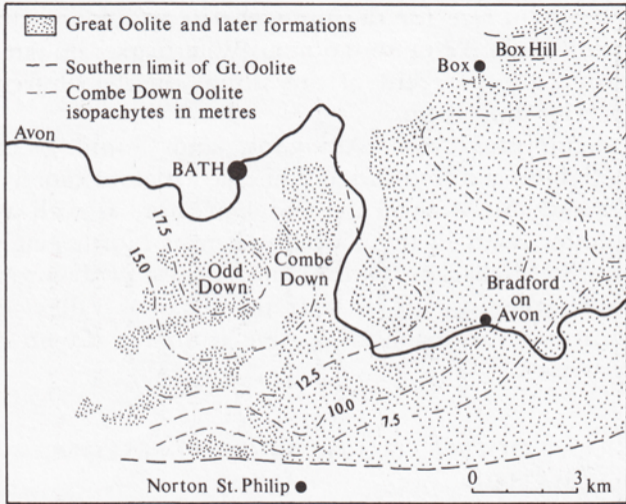

FIGURE 6  
 Isopachytes of the Combe Down Oolite

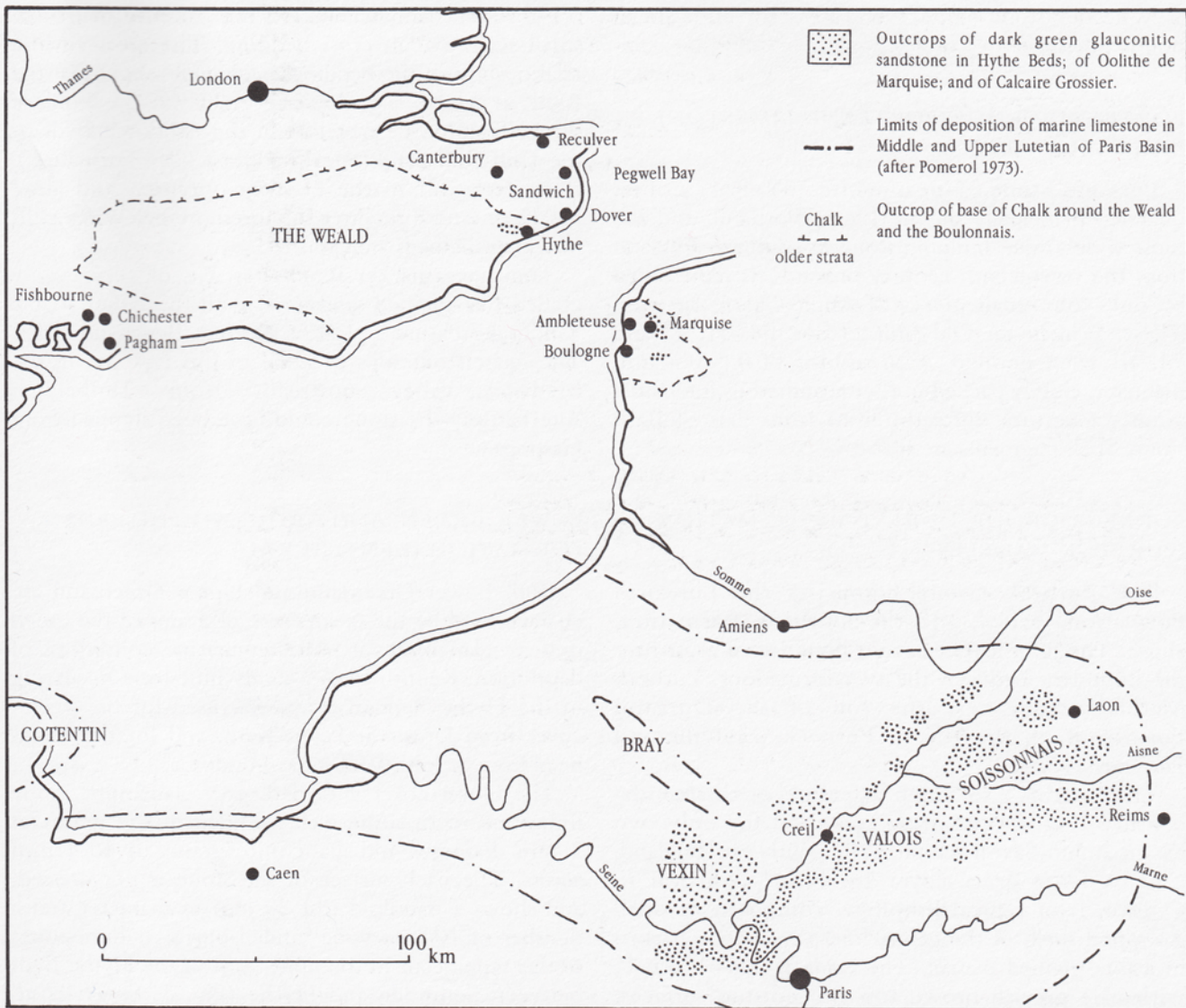

FIGURE 7

Sources of stone in east Kent and northern France used for Anglo-Saxon sculptures



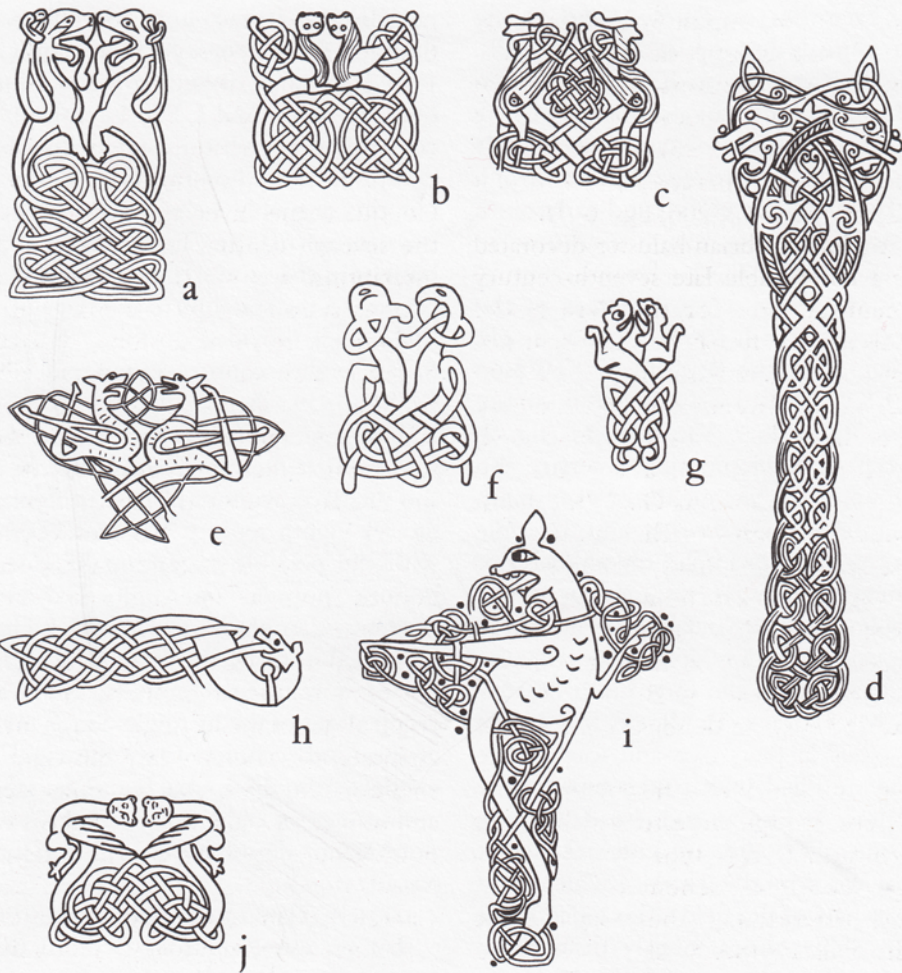

FIGURE 8

Animal types, nts (KEY: a, Elstow 1A; b-c, Gandersheim casket; d, York, Coppergate helmet; e, Witham pins; f, Maaseik, embroideries; g, BL MS Royal I.E.VI, fol 4r; h, Pentney brooch; i, Leningrad Gospels, fol. 16r; j, Peterborough, 'Hedda' stone)



a



b



c

### FIGURE 9

Steventon 1, Animal types, nts (KEY: a, face B, upper; b, face A; c, face B, lower)



a



b



c



d



e



f



g

FIGURE 10

Animal types, nts (KEY: a, Winchester Upper Brook Street 1A; b, Ramsbury; c-e, Tenbury; f-g, Colerne)



a



b



c



d



e



f

FIGURE 11

Animal types, nts (KEY: a-b, West Camel; c-d, Dolton; e, Gloucester; f, Ramsbury)

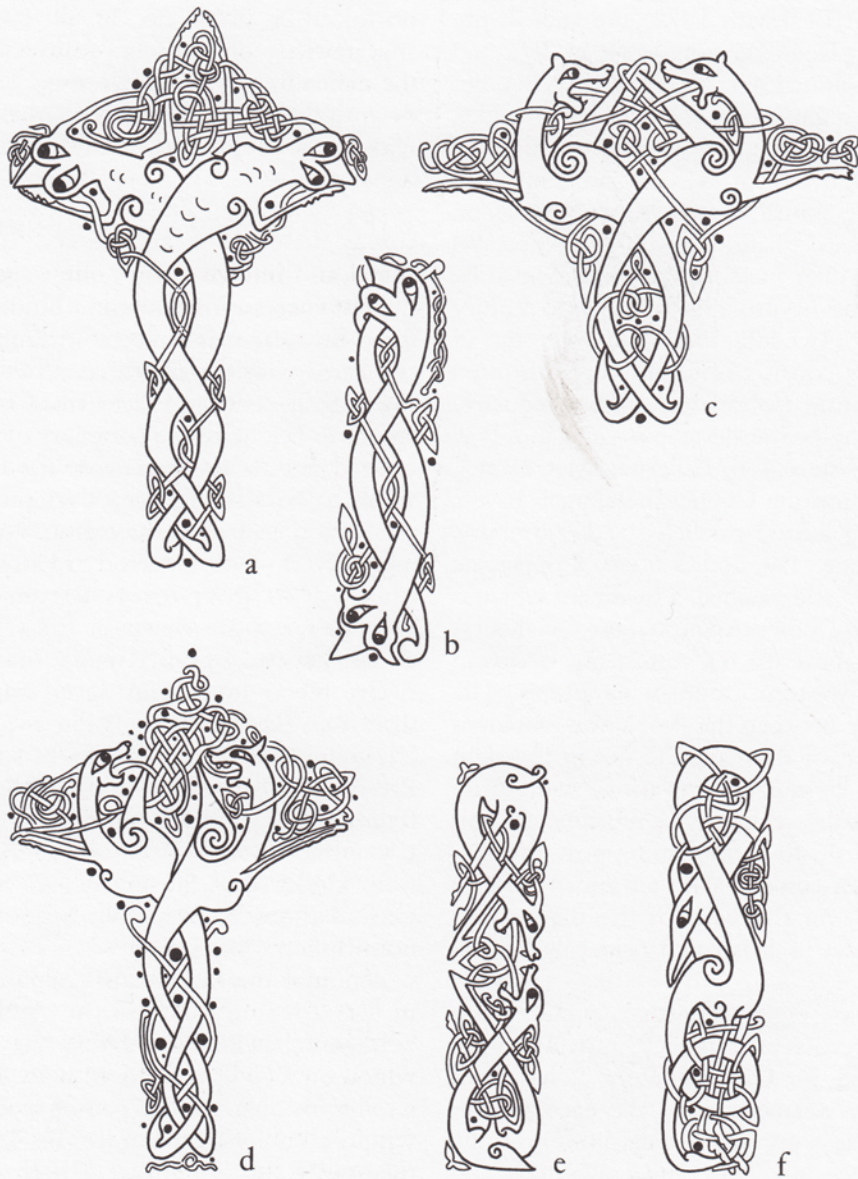

FIGURE 12

Animal types, Leningrad Gospels (after Schröde 1974, nts) (KEY: a, fol. 16r; b, fol. 16v; c, fol. 12r; d, fol. 16v; e, fol. 12v; f, fol. 12r)



a



b



c



d



e



f



g

FIGURE 13

Tree scrolls in semicircular fields, nts (KEY: a, Whitchurch 1C; b-c, Lilleby mount; d, Hedeby disc; e-f, Komnes disc; g, Tessem mount)



a



b

FIGURE 14

Inhabited Acanthus scrolls, nts (KEY: a, Oxford New Examination Schools 1A; b, Cambridge, Corpus Christi College MS 183, fol. 1v)



a



b

FIGURE 15

Foliate ornament, nts (KEY: a, Fuller brooch; b, Pentney brooch)



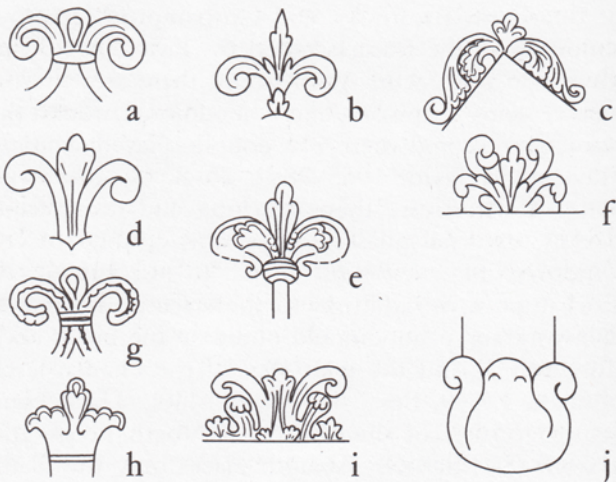

FIGURE 16

Foliate ornament, nts (KEY: a, York, Coppergate disc brooch; b, New York, Pierpont Morgan Library MS 709, fol. 2v; c, Athelstan Psalter, fol. 21r; d, Lincoln, ivory seal matrix; e, Winchester New Minster foundation charter, fol. 2v; f, Cambridge, Pembroke College MS 301, fol. 10v; g, London, Cheapside hoard disc brooch; h, Junius Psalter, fol. 118r; i, BL MS Harley 2904, fol. 4r; j, Corhampton 2)



a



b



c



d

FIGURE 17

Foliate ornament, nts (KEY: a, Damme, gospel lectionary;  
b, Aelfric's Pentateuch, fol. 2r; c, Canterbury, censer cover;  
d, Cambridge, University Library MS Ff.1.23, fol. 171r)

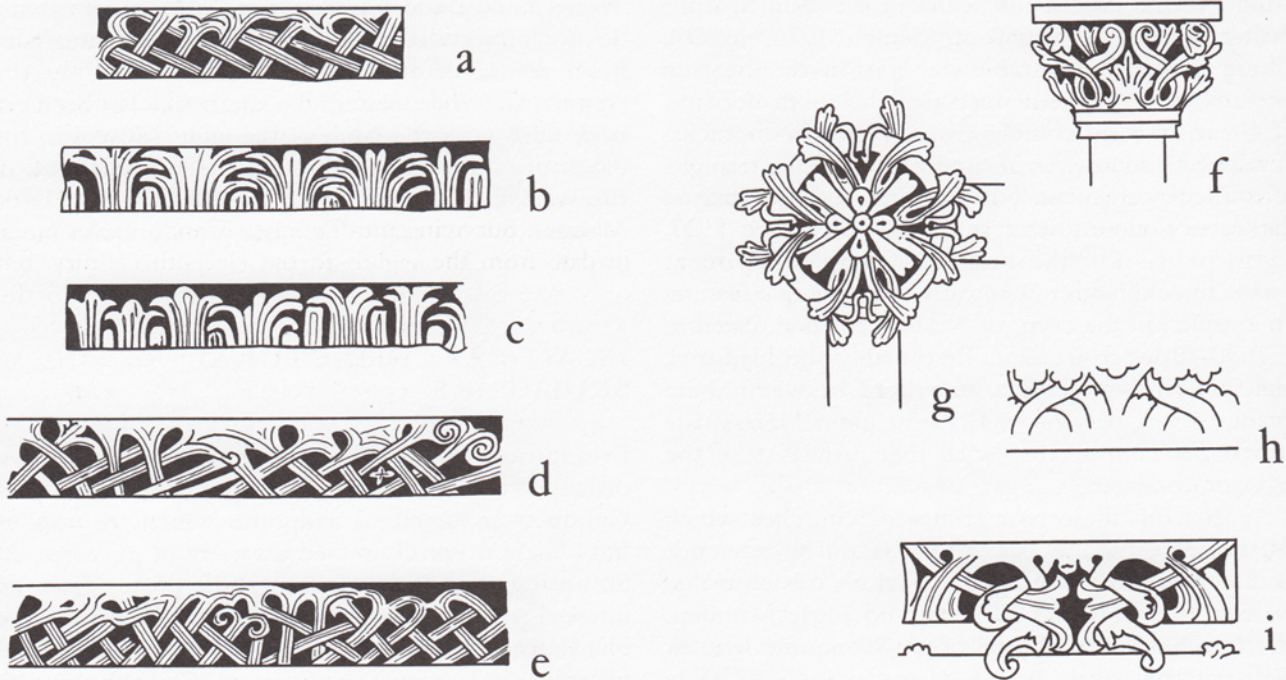

FIGURE 18

Foliolate ornament, nts (KEY: a, Sompting 7; b, Sompting 8; c, Sompting 6; d, Sompting 5; e, Sompting 4; f, Arenberg Gospels, fol. 17v; g, Oxford, Bodleian Library MS Tanner 3, fol. 1v; h, BL MS Cotton Vitellius C.III, fol. 11v; i, Rome, Vatican Library MS Reg. Lat. 12, fol. 62r)

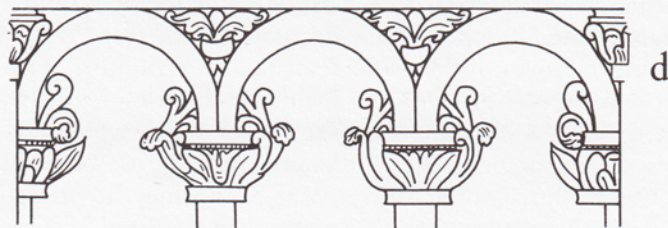
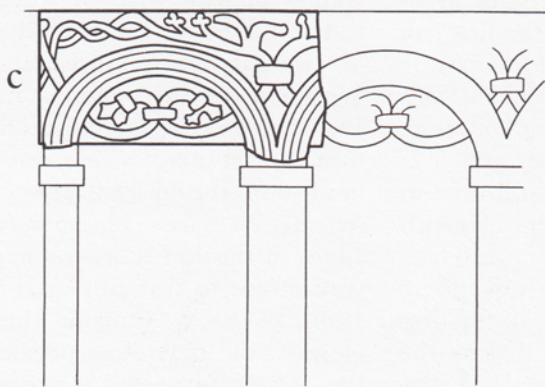
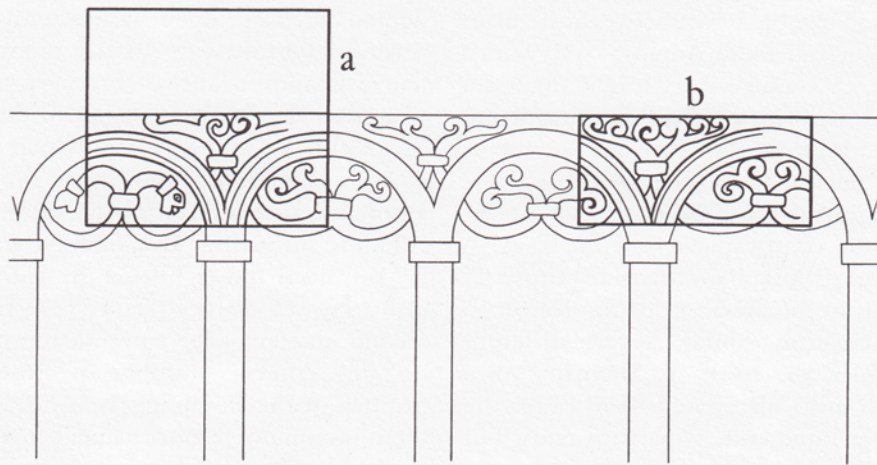

FIGURE 19

Sompting 9–11, reconstructions, nts (KEY: a, 11A; b, 10A; c, 9A; d, Cambridge, Trinity Gospels, fol. 11r)

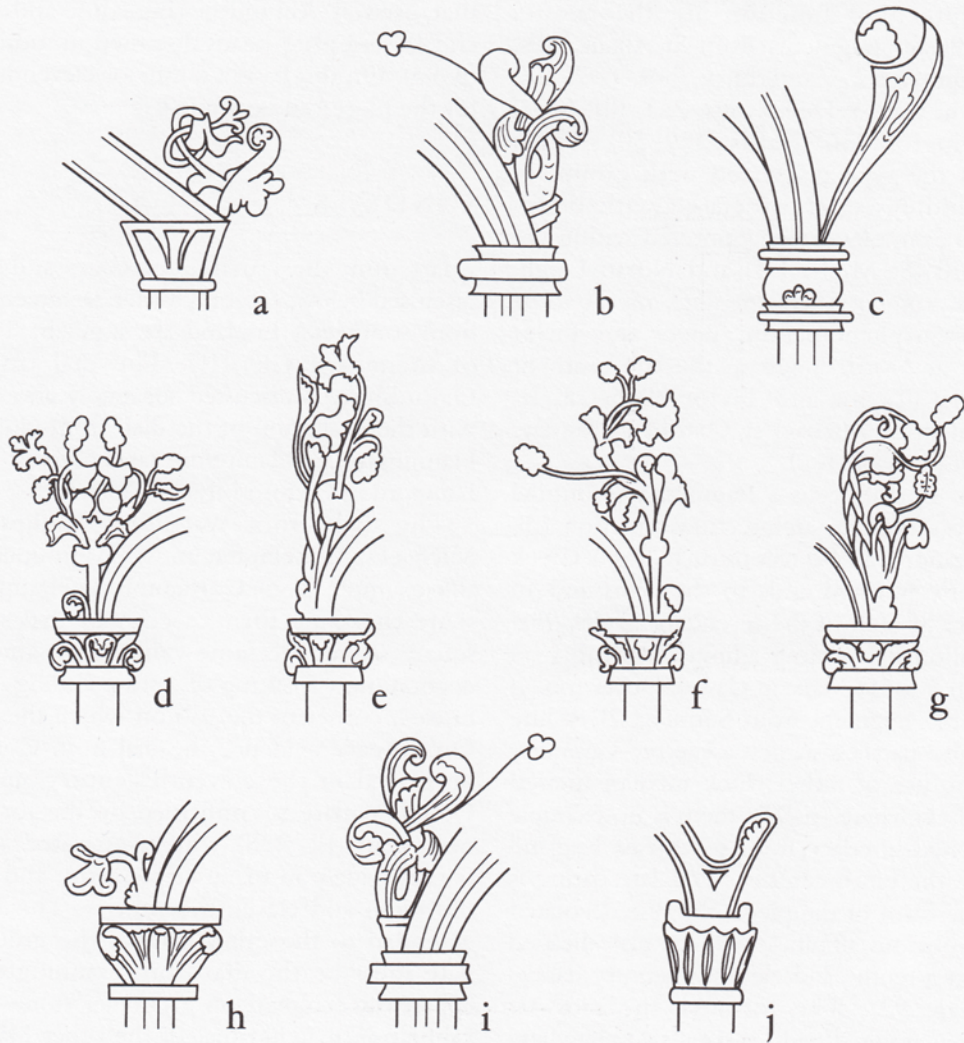

FIGURE 20

Foliate ornament, nts (KEY: a, Warsaw, Biblioteka Narodowa MS I.3311, fol. 15r; b and i, Eadui Codex, fol. 10r; c, BL MS Arundel 155, fol. 133r; d-g, Monte Cassino MS BB.437, 439, pp. 126-7; h, Bury Gospels, fol. 8v; j, Sompting 13)

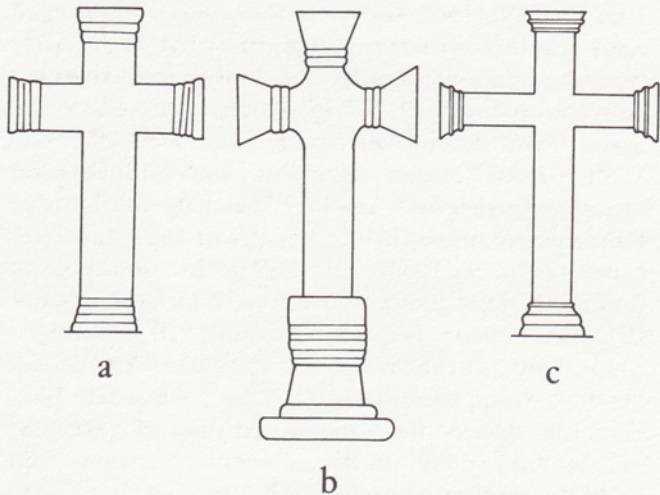

FIGURE 21

Cross forms, nts (KEY: a, London Stepney 1; b, Weyhill 1A; c, Arenberg Gospels, fol. 9v)



a



b



c

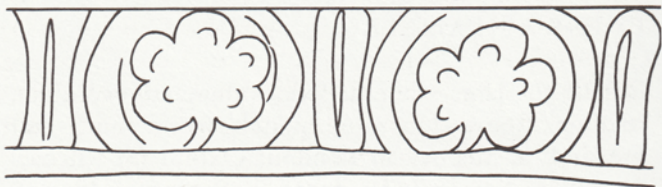

d

FIGURE 22

Foliolate ornament, nts (KEY: a, Chichester, Romanesque panels; b, Rheims, Bibliothèque Municipale MS 9, fol. 23r; c, Winchester Psalter, fol. 9r; d, London Stepney 1)

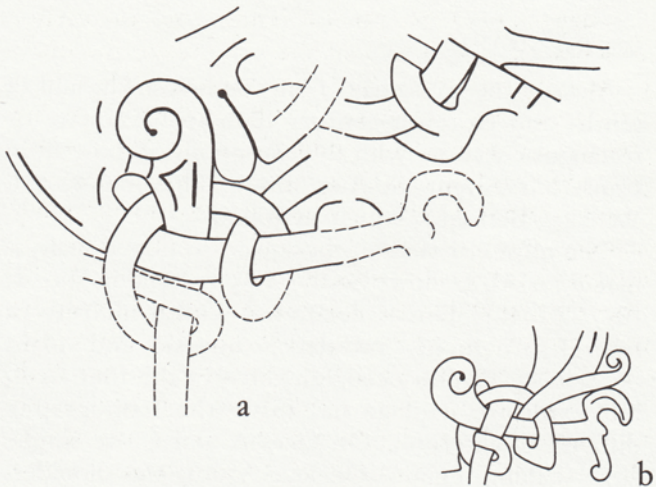

FIGURE 23

Animal ornament, nts (KEY: a, London All Hallows 3A (partially reconstructed); b, London St Paul's 1A, detail)



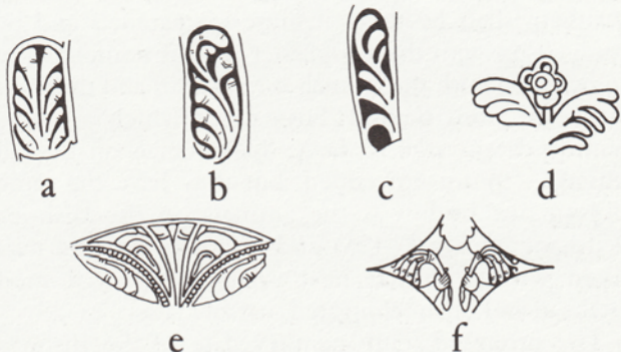
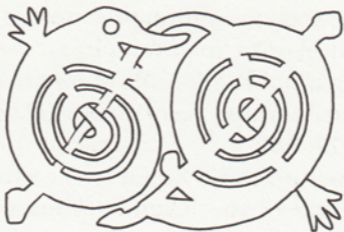

FIGURE 24

Foliate ornament, nts (KEY: a–b, Abingdon sword; c, sword from river Seine, Paris; d, Winchester, disc brooch; e, Stockholm, disc brooch; f, Fuller brooch)



a



b

FIGURE 25

Animal ornament, nts (KEY: a, Bishops Waltham 1C; b, Gloucester)

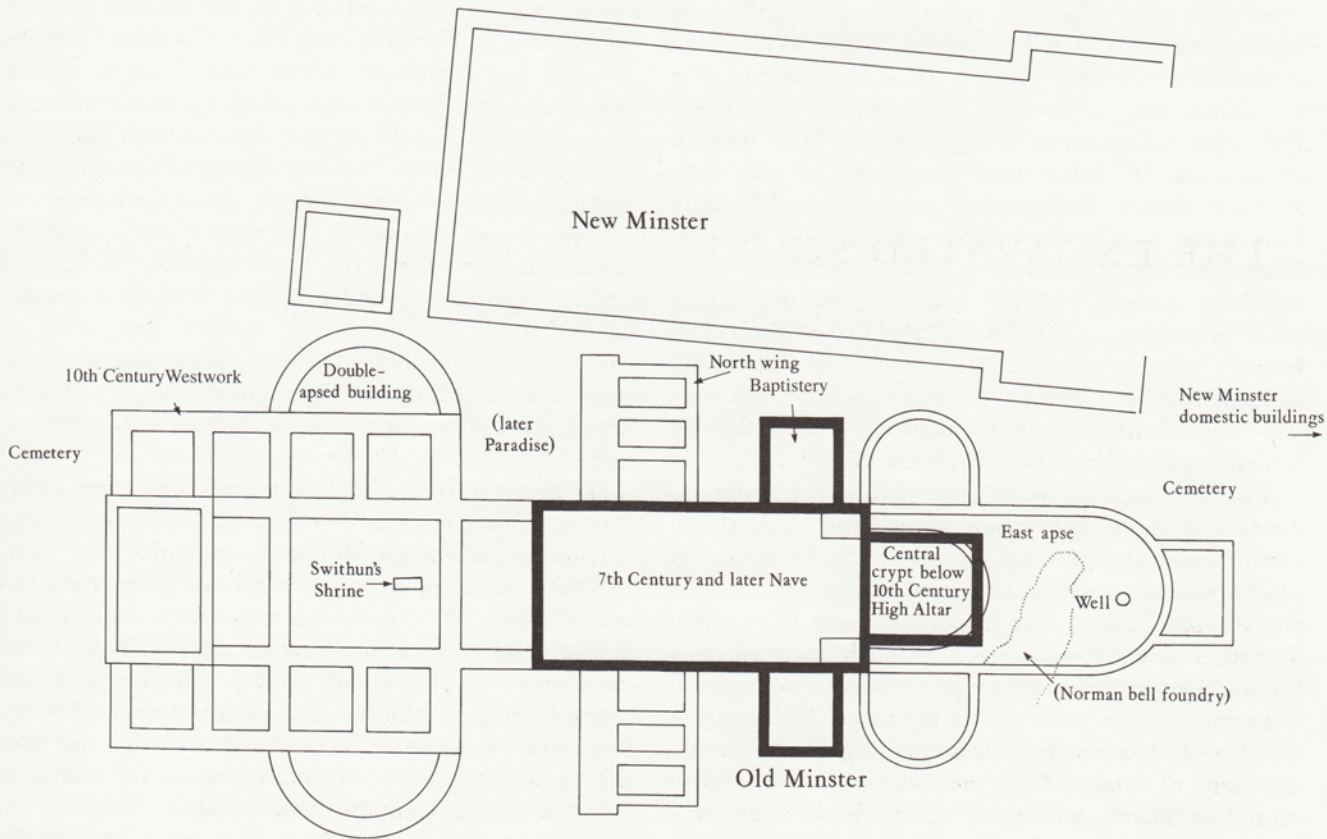

FIGURE 26

Winchester Old Minster, parts of church mentioned in text (post-demolition features in brackets)

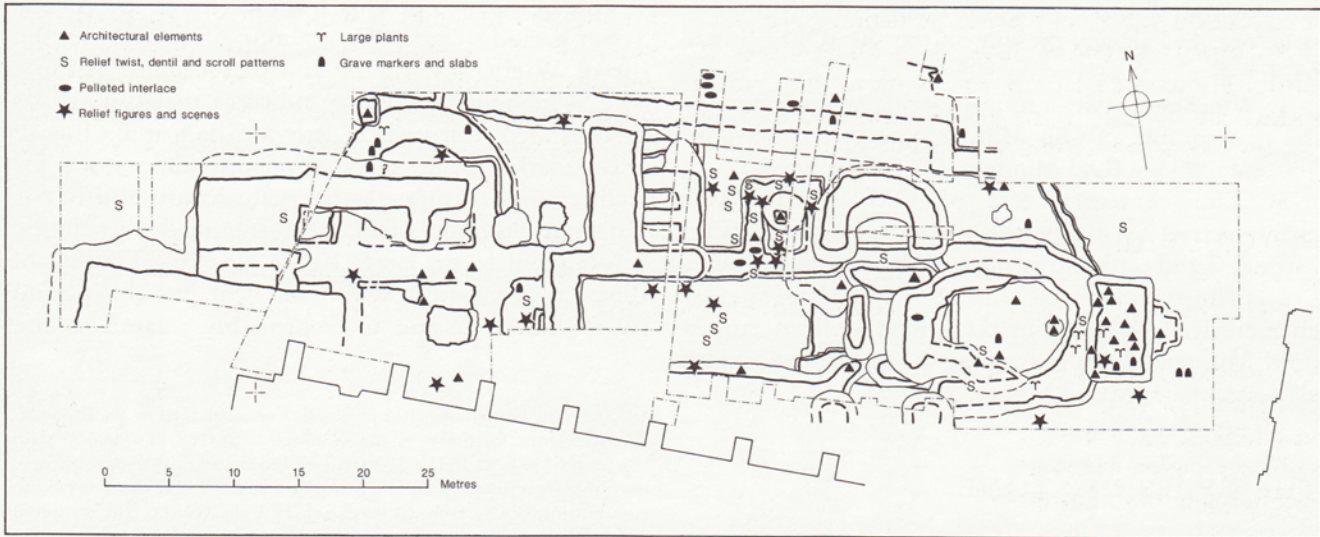

FIGURE 27

Winchester Old Minster, trench-plan showing find-spots and ornament type of carved fragments

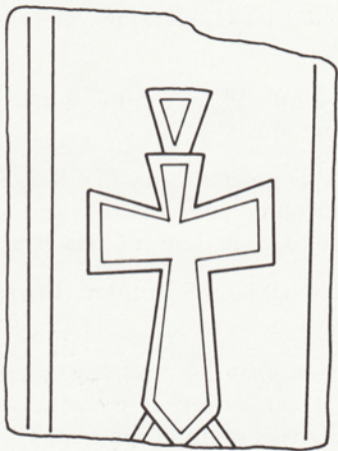

FIGURE 28  
Arundel 1A, nts

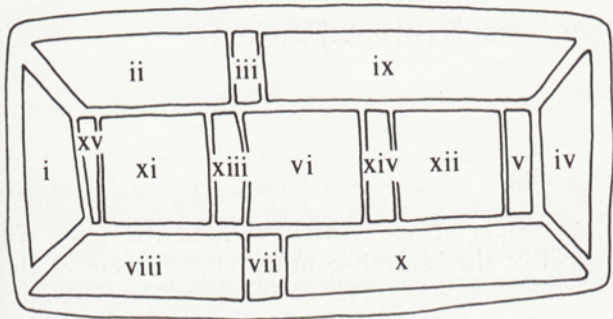
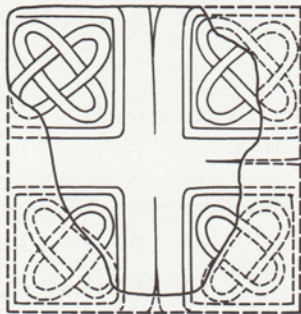
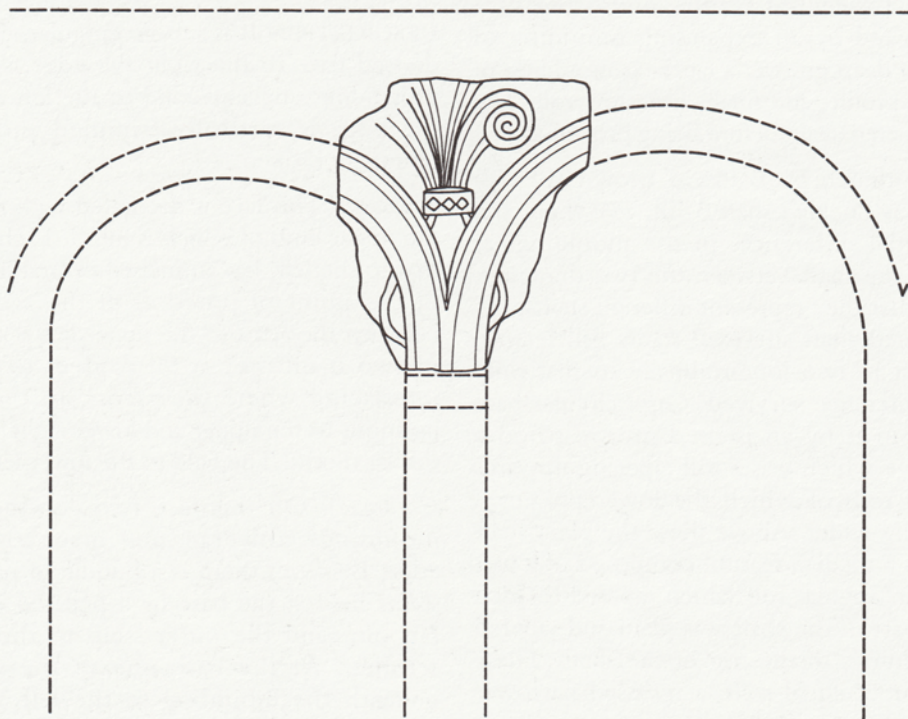

FIGURE 29

Bexhill 1A, labelling of panels, nts



a



c

FIGURE 30

Dover St Mary in Castro 4, reconstruction, nts (KEY: Letters as Faces in Description)

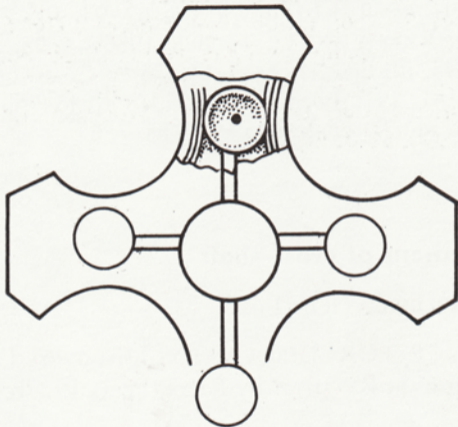

FIGURE 31

Reculver 3A, reconstruction, nts





FIGURE 32  
Great Canfield 1A, nts

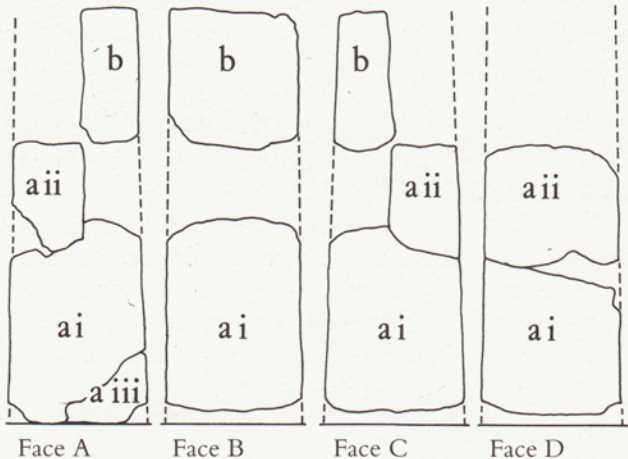

FIGURE 33

London All Hallows 1, labelling of fragments and faces, nts

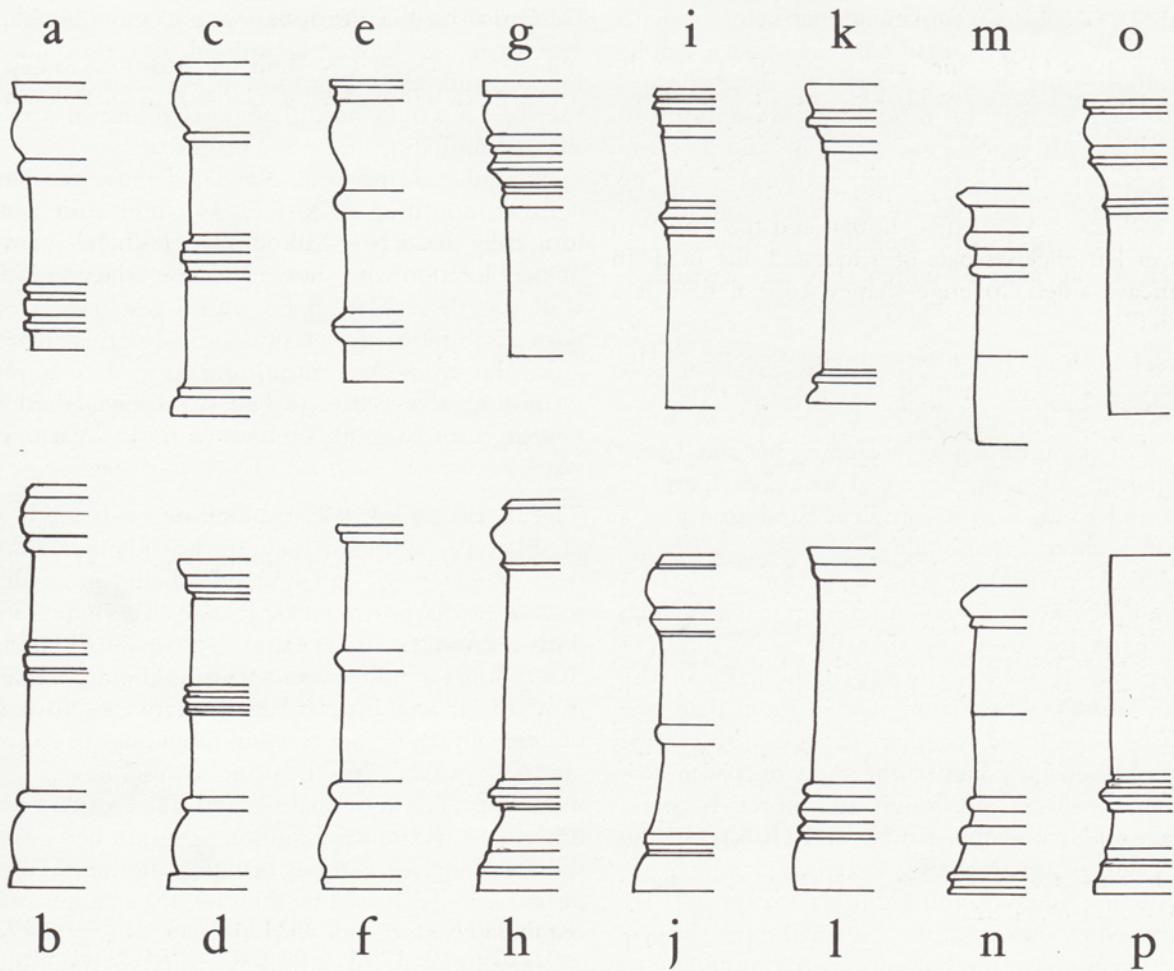

FIGURE 34

St Albans 1, Profiles of baluster shafts (1:16)

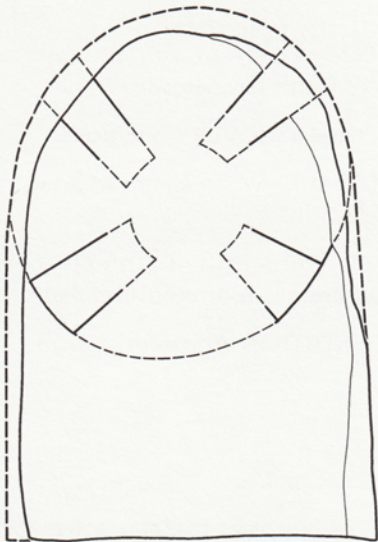

FIGURE 35

White Notley 1A, reconstruction, nts

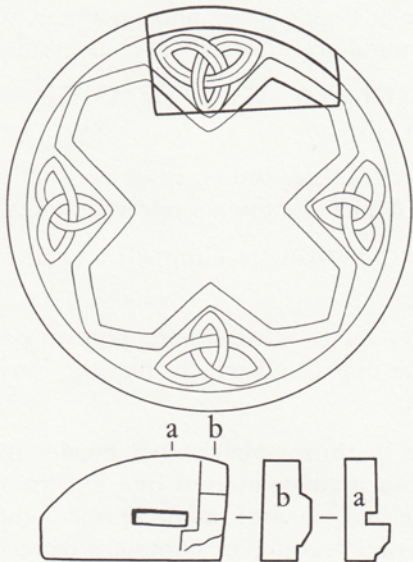

FIGURE 36

Abingdon 1A, reconstruction and cross-sections, nts

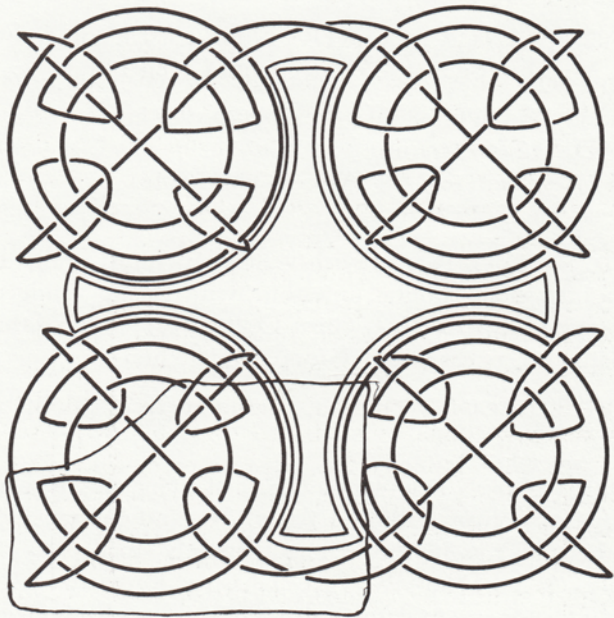

FIGURE 37  
Sonning 1, reconstruction, nts



a



b

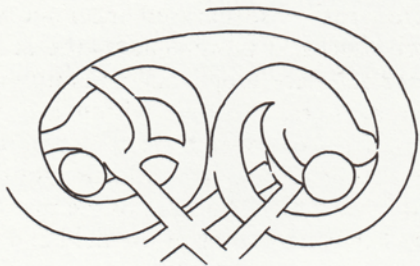

c



d

FIGURE 38

South Hayling 1, partial reconstruction of ornament, nts (KEY: Letters as Faces in Description)

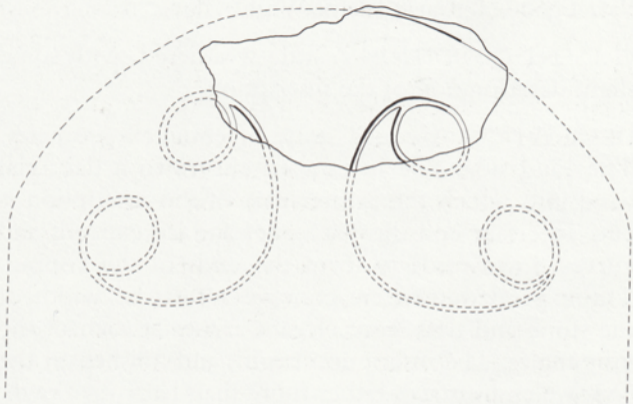

FIGURE 39

Winchester Old Minster 5A, reconstruction, nts



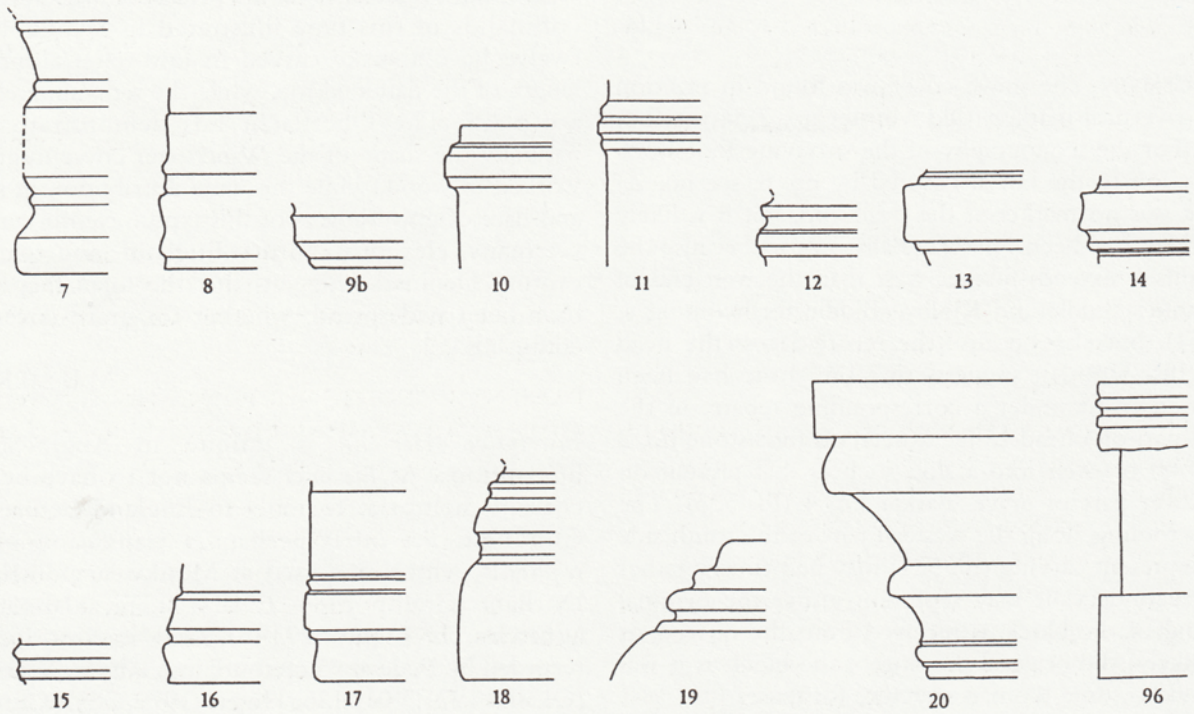

FIGURE 40

Winchester Old Minster, profiles of bases and baluster shafts (1:8 approx., not half-diameters)

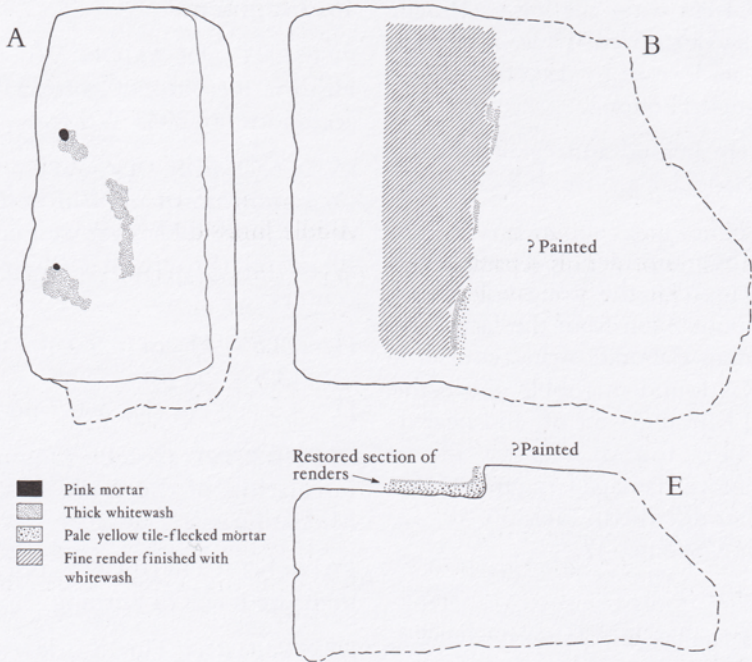

FIGURE 41

Winchester Old Minster 43, distribution and stratigraphy of renders

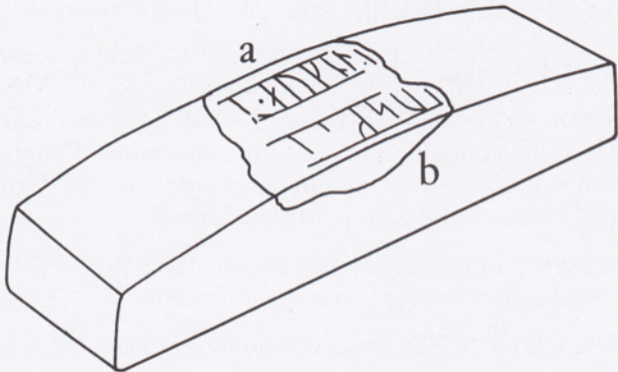

FIGURE 42

Winchester St Maurice 1, reconstruction, nts

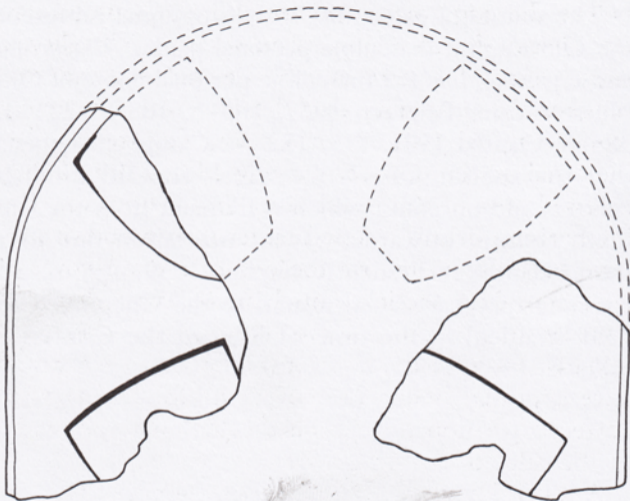

FIGURE 43

Winchester Old Minster 94a-bA, reconstruction, nts

TABLE 1. Stratigraphical divisions in southern England and northern France

NOTE: Broken lines indicate gaps in the geological record; asterisks mark lithostratigraphical units that yielded stone for Anglo-Saxon sculptures.

ERA	PERIOD	LITHOSTRATIGRAPHICAL UNITS IN SOUTH- EAST ENGLAND	SOME FORMATIONS IN NORTH FRANCE
QUATERNARY	RECENT PLEISTOCENE	'Drift' deposits (*?) 'Drift' deposits -----	
TERTIARY	PALAEOGENE	Hamstead Formation Bembridge Formation* Solent Formation(*?) Barton Formation Bracklesham Group London Clay Reading Beds Thanet Beds* -----	Calcaire Grossier*
MESOZOIC	UPPER CRETACEOUS LOWER CRETACEOUS	Chalk Group* Gault Group Upper Greensand* Gault Lower Greensand Group* Wealden Group* Purbeck Group Durlston Formation* Lulworth Formation	
	UPPER JURASSIC	Portland Group* Ancholme Group Kimmeridge Clay Corallian Beds* Oxford Clay Kellaways Beds	
	MIDDLE JURASSIC	Great Oolite Group*	Oolithe de Marquise* Calcaire de Caen*
	LOWER JURASSIC	Inferior Oolite Group* Lias Group	

TABLE 2. Carved stones from Old and New Minsters: summary of archaeological contexts

CONTEXT	NUMBER OF STONES	PERCENTAGE
Anglo-Saxon layers (see Table 7)	12	11.3
Demolition of 1093-4	27	25.5
Final infill of 1093-4	30	28.3
Robbing of New Minster	5	4.7
Final robbing of Old Minster	9	8.5
Later layers	20	18.9
Building E	3	2.8

TABLE 3. Carved stones from the Old and New Minsters and other Winchester sites excavated in 1961-71: buildings and stone types

NOTE: Column percentages are given in brackets immediately after the number of stones which they represent.

STONE TYPE	STONES	OLD MINSTER	NEW MINSTER	GRAVE-MARKERS
Combe Down Oolite	88	75 (86.2%)	5 (100%)	8 (55.3%)
Quarr	6	2 (2.3%)	-	4 (26.7%)
Portland	4	4 (4.6%)	-	-
Calcaire Grossier	2	2 (2.3%)	-	-
Binstead	2	-	-	2 (13.3%)
Great Oolite Group	2	1 (1.1%)	-	1 (6.7%)
Bembridge Limestone	1	1 (1.1%)	-	-
Lower Chalk	1	1 (1.1%)	-	-
Purbeck Marble	1	1 (1.1%)	-	-
TOTALS	107	87	5	15

TABLE 4. Grave-markers from the Winchester excavations of 1961-71: sources and stone types

STONE TYPE	OLD MINSTER	NEW MINSTER	LOWER BROOK STREET	ST PANCRAS
Coombe Down Oolite	7	-	1	-
Quarr	1	2	-	1
Binstead	2	-	-	-
Great Oolite Group	1	-	-	-
TOTALS	11	2	1	1

TABLE 5. Winchester grave-markers: chronology and stone type

ASSIGNED DATE	STONE NO.	STONE TYPE
pre 901-3	OM 1	Combe Down Oolite
late 10th century	OM 3	Combe Down Oolite
late 10th to early 11th century	NM 1	Quarr
	NM 2	Quarr
	SP1	Quarr
	OM 5	Great Oolite Group
early 11th century	OM 2	Binstead
	OM 6	Binstead
early to mid 11th century	OM 4	Combe Down Oolite
mid to late 11th century	OM 92	Quarr
	OM 93	Combe Down Oolite
	OM 94A	Combe Down Oolite
	OM 94B	Combe Down Oolite
	OM 95	Combe Down Oolite
11th century	LBS 1	Combe Down Oolite

TABLE 6. Architectural and decorative carved stones from Old Minster: chronology and stone types other than Combe Down Oolite

ASSIGNED DATE	STONE NO.	STONE TYPE
7th century?	OM 38	Portland
	OM 41	Portland
	OM 42	Portland
	OM 74	Portland
late 9th century or earlier	OM 63	Bembridge Limestone
9th to 10th century	OM 64	Lower Chalk
10th century or earlier	OM 12	Calcaire Grossier
	OM 19	Calcaire Grossier
	OM 32	Quarr
	OM 91	Great Oolite Group
late 10th century	OM 85	Purbeck marble
mid to late 11th century	OM 96	Quarr